

## Core Barrel

<b>Kelly Box Options</b>	Optional sizes available including 130×130 mm, 150×150 mm, 200×200 mm, and more.
<b>Cutting Tools</b>	Available with bullet teeth or various types of roller bits.
<b>Large Drilling Diameter</b>	Supports drilling diameters up to 5000 mm.
<b>Round Shank Chisels</b>	Designed with durable round shank chisels.
<b>Custom Cutting Diameters</b>	Different cutting diameters can be customised to suit project requirements.
<b>Custom Shell Configuration</b>	Shell heights and teeth quantities can be customised.
<b>Reinforced Components</b>	Key structural components can be reinforced for demanding applications.
<b>Rig Compatibility</b>	Compatible with most rotary drilling rigs including Bauer, IMT, Soilmec, Casagrande, Mait, XCMG, and others.

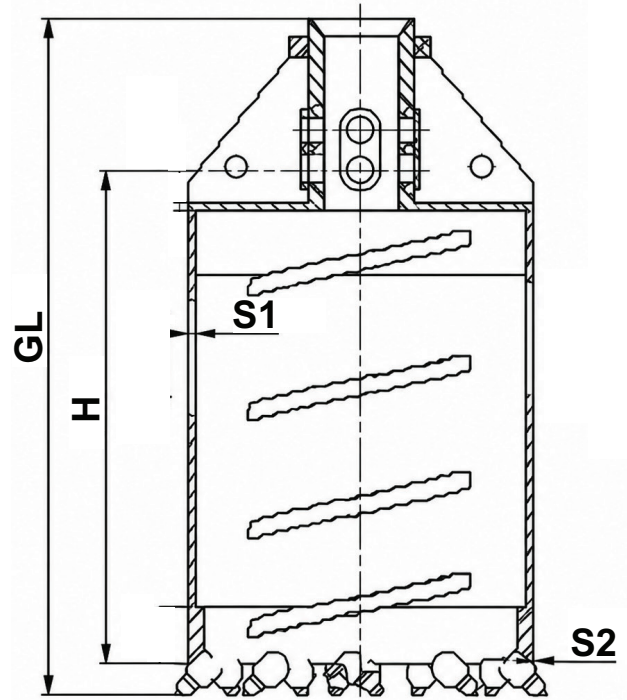

Cutting Diameter	Shell Diameter	Height	Shell Height	Shell Thickness	Cutting Ring Thickness
mm	mm	GL mm	H mm	S1 mm	S2 mm
600	520	1750	1200	16	30
700	620	1750	1200	16	30
800	720	1750	1200	16	30
900	820	1750	1200	16	30
1000	920	1750	1200	16	30
1200	1120	1750	1200	16	30
1300	1220	1750	1200	16	30
1500	1420	1750	1200	16	30
1800	1720	1550	1000	20	40
2000	1920	1350	800	20	40
2200	2120	1350	800	20	40
2500	2420	1350	800	20	40

Note: The above sizes for reference, any smaller or larger OD as per request.