

The FR35 Small Kelly Bar Drill Attachment is a compact and powerful drilling solution **designed for low-headroom and restricted-access foundation projects**. Ideal for use under bridges, power lines, and inside buildings, the attachment **delivers up to 35kN·m drilling torque**, a maximum drilling diameter of 1,000mm, and **drilling depths up to 13m** when paired with a suitable carrier machine.

Built using premium globally recognised components including Yanmar, Rexroth, and Bonfiglioli systems, the FR35 drill attachment is **engineered for reliability**, simplified servicing, and reduced downtime. Manufactured in Asia for cost and delivery efficiency to Australia, the attachment is supplied ready for integration and **backed by a 12-month / 2,000-hour warranty**.

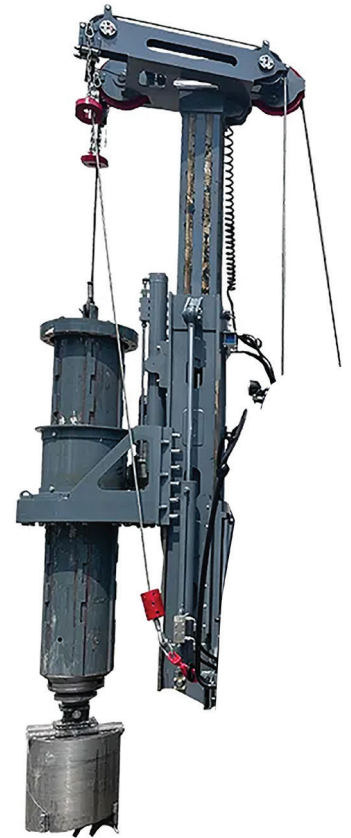

Item	Manufacturer	Standard (Australian / European Equivalent)
Mast Steel Grade	Q355 / Q460	GB/T 1591-2018 (AS/NZS 3679.1)
Kelly Bar Steel Grade	Q355 / Q46 / 27SiMn	GB/T 8162 (AS/NZS 1163) / GB/T 3077-2018 (EN 10083)
Rotary Drive	Motor-Danfoss	ISO 4413 (AS 4024.3301)
Hydraulic Components	Rexroth / Kawasaki	ISO 4413 (AS 4024.3301)
Hydraulic Hoses	Gates / Continental	EN853-1SN / EN853-2SN / EN857-4SH
Bolt Grade	≥8.8 grade	GB/T 3098.1-2010 (AS/NZS ISO 898-1) / GB/T 18684-2002 (AS 1418)
Sheave Bearings	SKF / FAG	GB/T 10051 (AS 3775)
Hooks and Wire Rope	35WK7 grade	GB/T 19001-2016 (ISO 9001:2015)
Welding Standards		JB/T 5943-2018 (AS/NZS 1554.1)

SPECIFICATIONS

Description		Units
Rotary Head	Maximum Output Torque	35kN.m
	Drilling Speed	0-50rpm
Maximum Drilling Diameter		1000mm
Maximum Drilling Depth		13m
Crowd Cylinder	Maximum Pressure	55kN
	Max. lifting force	60kN
	Stroke	1000mm
Main Winch	Maximum Lifting Force	50kN
	Maximum Lifting Speed	50m/min
	Rope Diameter	16mm
Auxiliary Winch	Maximum Lifting Force	20kN
	Maximum Lifting Speed	50m/min
	Rope Diameter	16mm
Mast Inclination	Lateral Inclination	±4°
	Forward Inclination	5°
Interlocking Kelly Bar		13m
Hydraulic System	Working Pressure	28MPa
Operating Weight		9500kg

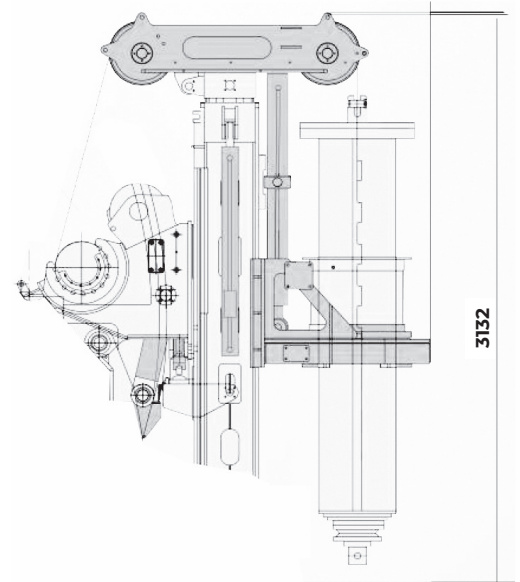
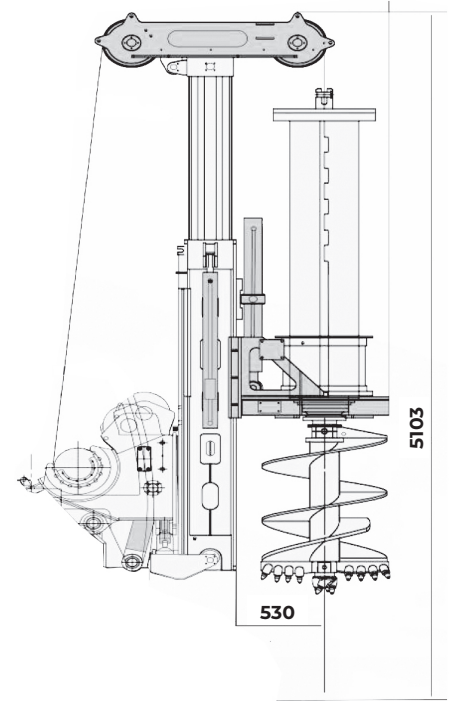

For more information about the FR35 Small Piling Machine Attachment or to discuss your drilling and foundation requirements, contact the team at CESCO Equipment. Our specialists can assist with attachment selection, technical advice, and tailored equipment solutions for restricted-access and foundation drilling applications.